



DESCRIPTION

The models of the Idea line catches the eye for cutting-edge design and the smart functions of the 5"-TFT touchscreen, which transform the concept of vacuum packaging machine into "Sous Vide Robot": specific "Chef "and deaeration cycles allow food processing, which make it a versatile and multi-purpose work tool, suitable for the catering sector.



SEALING BAR 16.1 inch
VACUUM PUMP 706 cf/h
ABSOLUTE SENSOR
CONTROL

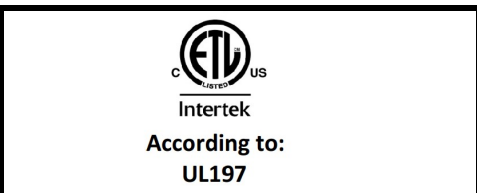

FEATURES

- Oil lubricated 706 cf/h (20 m³/h) vacuum pump ;
- Vacuum level control through high precision absolute-type vacuum sensor, which does not require calibration; max vacuum 99,8% (2 millibar);
- 16,1" sealing bar, easily removable for cleaning;
- Hydroformed, brilliant stainless steel vacuum chamber with constant thickness, easy to clean being free of edges and receptacles;
- Standard inert gas injection with 2 injection nozzles with "Gasplus" system, which allows to reach values up to 90% of inert gas for products extremely sensitive to crushing;
- Standard "Softair" slow air return at the end of the cycle;
- Waterproof 5"-TFT touchscreen control panel, protected by scratch-resistant tempered glass, resistant to liquids, humidity, dirt and dust;
- 10 editable user programs, with assignable names; 5 settable display languages;
- 9 preset "Chef" cycles for food processing;
- 3 specific preset cycles with inert gas injection;
- 3 specific preset cycles for vacuum containers;
- 2 generic preset cycles for preservation or sous vide cooking;
- 1 programmable deaeration ("Degas") program on eight vacuum phases and eight pause phases;
- "H2Out" pump oil dehumidification cycle,
- Notice of need for oil change, "H2OUT" cycle execution or product cooling need in case of use of insufficiently cooled wet products;
- Menu accessible to technical assistance for parameter adjustment and reading of cycle and maintenance carried out;
- High-thickness blued PMMA (Plexiglass) lid with polished and rounded edges; opens automatically at the end of the cycle;
- Lowering system of the lid at the end of the work in the rest position by releasing the rear gas spring, which allows to release the tension on the gas spring and on the lid;
- Access for easy maintenance through front opening of the casing;
- Standard "Easy" accessory for external vacuum in embossed bags;
- 3 PE-filling plates for product adjustment and cycle speed up;

ACCESSORIES (NOT INCLUDED)

- Bags for storage, cooking and "cook & chill"; embossed bags;
- Stainless steel cart with castors and shelf;
- Inclined stainless steel plate for liquid packing;
- Stainless steel vacuum containers; suction device.

PROJECT	DATE	APPROVED
ITEM	QTY	

VACUUM PACKAGING MACHINES IDEA 42

UPDATED:
01/03/2022

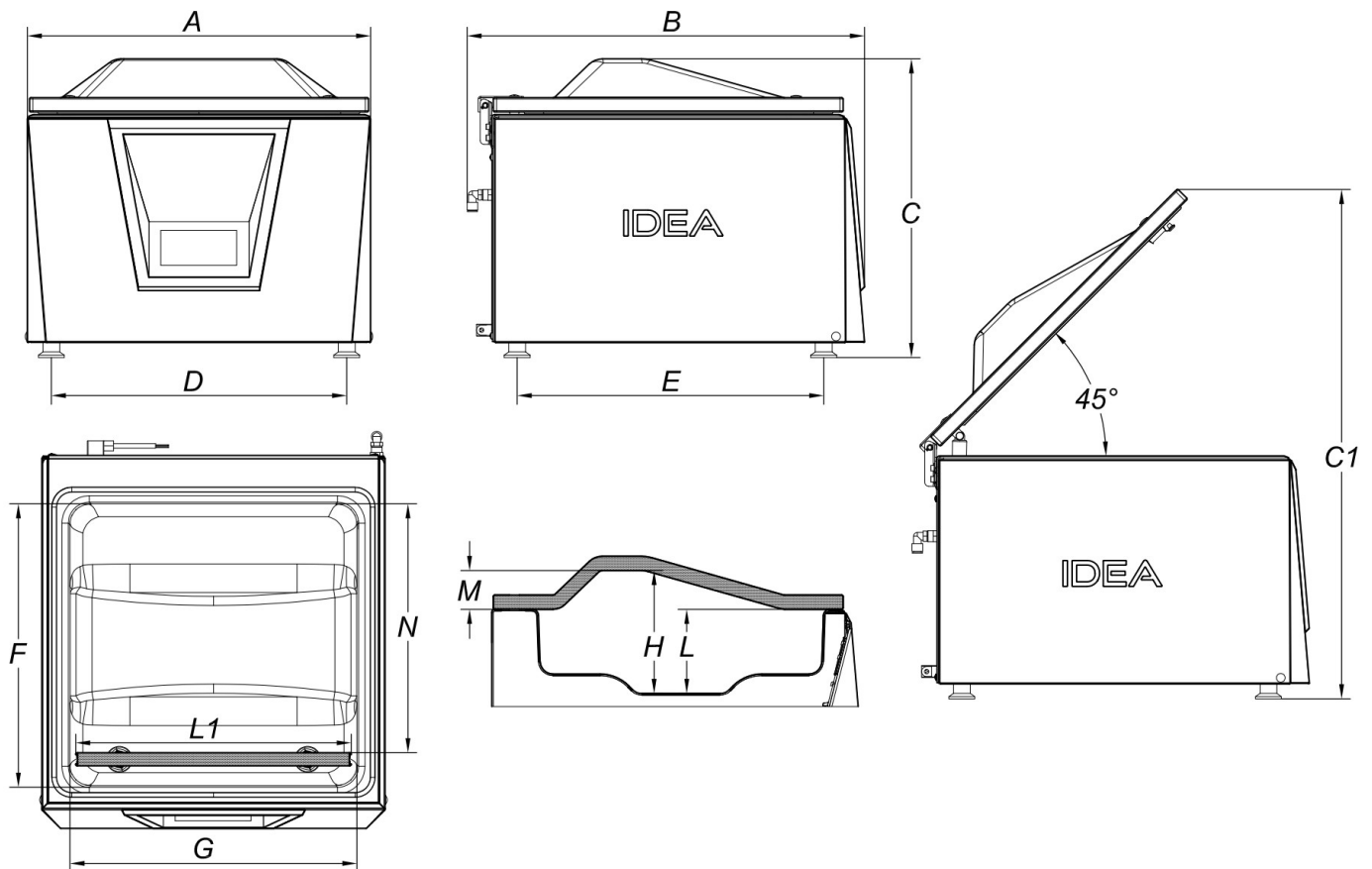

SPECIFICATIONS

Length of seal L1	inch	16,1
Nominal pump speed	cf/h	706
Final pressure	mbar	2
Chamber size (FxGxH)	inch	17,3x17,6x7,5
Useful chamber space (N)	inch	15,2
Chamber depth (L)	inch	5,1
Chamber volume	Usgal	6,86
Power	W	1300
Electrical voltage/Frequency/Phases	V/Hz	110V / 60Hz / 1Ph+N+PE
Power cord and plug		78,7 inch + IEC / Nema 5
Current	A	11,81
Housing materials		Stainless steel (AISI304)
Vacuum chamber material		Hydroformed stainless steel (AISI304)
Lid material		PMMA (plexiglas)
Overall dimensions (AxBxC)	inch	20,9x24,2x18,1
Maximum height with open lid (C1)	inch	31
Distance between supports (DxE)	inch	18x18,7
Weight (with shelves)	lbs	136,5
Noise level	dB(A)	65
Environmental operating temperature (min-max)	°F	53,6-104